

NOTES:

1. All Tankage, piping and installation provided by others. StormTEE® and treatment insert supplied by Bio-Microbics, Inc.®
2. Bio-Microbics® treatment insert must be sealed to tank lid using non-toxic sealant and concrete bolts. Bolts provided by others. See Plan view for suggested bolt pattern.
3. Treatment insert legs must be bolted to tank with a minimum of two bolts per leg. Bolts provided by others.
4. Legs are adjustable to any height using SCH 40 PVC pipe and Bio-Microbics supplied screws. If Legs are to be extended past 24" then Sch 80 PVC or Stronger Pipe must be used.
5. The entire treatment module should be level.
6. Tank shown as a two compartment tank, also possible to utilize two separate tanks
7. Required weir plate height and location shown with one example of a diversion box design.
8. Follow all applicable codes.

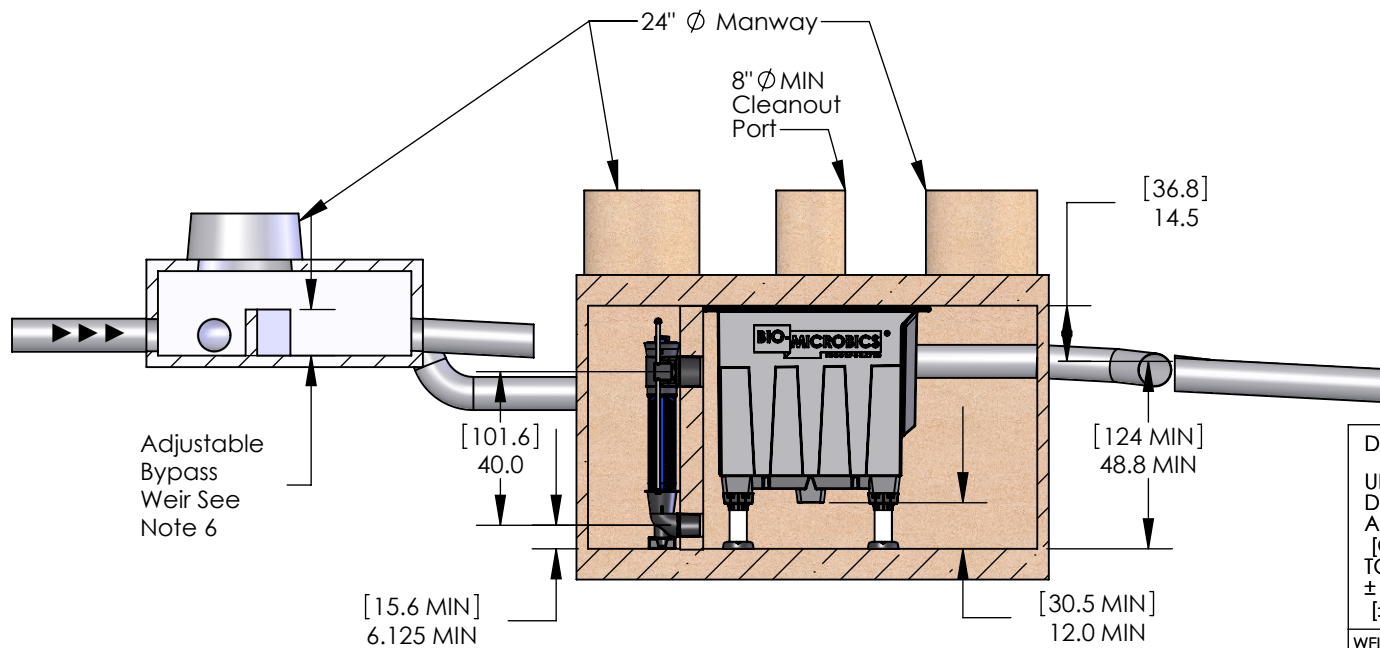

DO NOT SCALE
UNLESS NOTED
DIMENSIONS
ARE IN INCHES
[CENTIMETERS]
TOLERANCES
± 0.02 IN/IN
[± 0.05 CM/CM]



BIOSTORM

WEIGHT		lb	SIZE	DRAWING NUMBER		SHEET 1 OF 1
NAME	DATE		A	BioStorm® 0.5		
DRAWN	CTC	4/27/2006		REVISED	9/26/2011	
CHECKED	PF	9/26/2011		REV.	INI-01-A+	

THE INFORMATION CONTAINED IN THIS DRAWING IS THE SOLE PROPERTY OF BIO-MICROBICS INC. ANY REPRODUCTION IN PART OR AS A WHOLE WITHOUT THE WRITTEN PERMISSION OF BIO-MICROBICS INC. IS PROHIBITED. DESIGN AND INVENTION RIGHTS ARE RESERVED. IN THE INTEREST OF TECHNOLOGICAL ADVANCEMENT, ALL PRODUCTS ARE SUBJECT TO DESIGN AND OR MATERIAL CHANGE WITHOUT NOTICE.

BIO-MICROBICS © 2012